

Horizontal Torque Test Stand

The horizontal TTST-1 and TTST-2 are designed specifically for use with the TTC Torque Tool Tester. These rugged test stands enable a torque force to be tightly applied to various torque tools. The large adjustment wheel steadily moves a connected tool under test, such as a torque wrench, at the user-controlled rate to properly finalize a performance check. Both horizontal TTST's have a movement travel up to 7.9" (200 mm) on tool lengths from 5.9 to 23.6" (150-600 mm) on the TTST-1 and 5.9 to 43.3" (150-1100 mm) on the TTST-2.

These excellent features make the TTST Manual Torque Test Stands a valuable and versatile addition to performing tightly controlled torque tests.

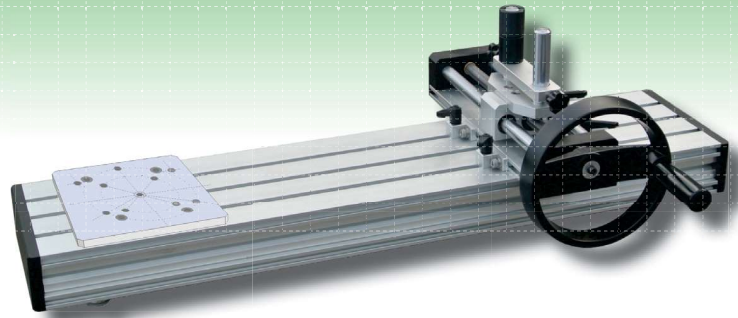

Testing TTC with Internal Sensor



Testing TTC with External Sensor

TTST-1 & TTST-2 Test Stand Specifications

Models	Arm Length (mm)	Loading Travel	Loading Force (max.)	Weight lb (kg)
TTST-1	150 - 600	7.9" (200 mm)	225 lb (102 kg)	27 (12)
TTST-2	150 - 1100			35 (16)

Dimensions (mm)

